



POLYCAN Portable Urinal Technical Information

General Overview

The "PK01-1000 PolyCan Portable Urinal" is designed for "Highrise Construction Sites". Lightweight and easily mobile on rubber tread wheels. Conveniently fits inside of the "Highrise Portable Restroom" for ease of portability up into a "Highrise Construction Site". Serviceable by unscrewing the spinweld plug located in the back of the urinal. Available from "Rid-It" to help stabilize odor are the cherry or lemon scented "CK01-0010** Urinal Blocks" cased in 3oz packages.

For shipping purposes, the wheel assembly is shipped in a bag. Assembly simply snaps into the groove located on the bottom of the tank.

Specifications

Height	35 in	88.9 cm
Width with Wheels	15.5 in	39.3 cm
Depth	21 in	53.3 cm
Weight Empty	16.35 lb	7.4 kg
Weight Full	109 lb	49.4 kg
Holding Tank Capacity	11 gal	41.6 ltr

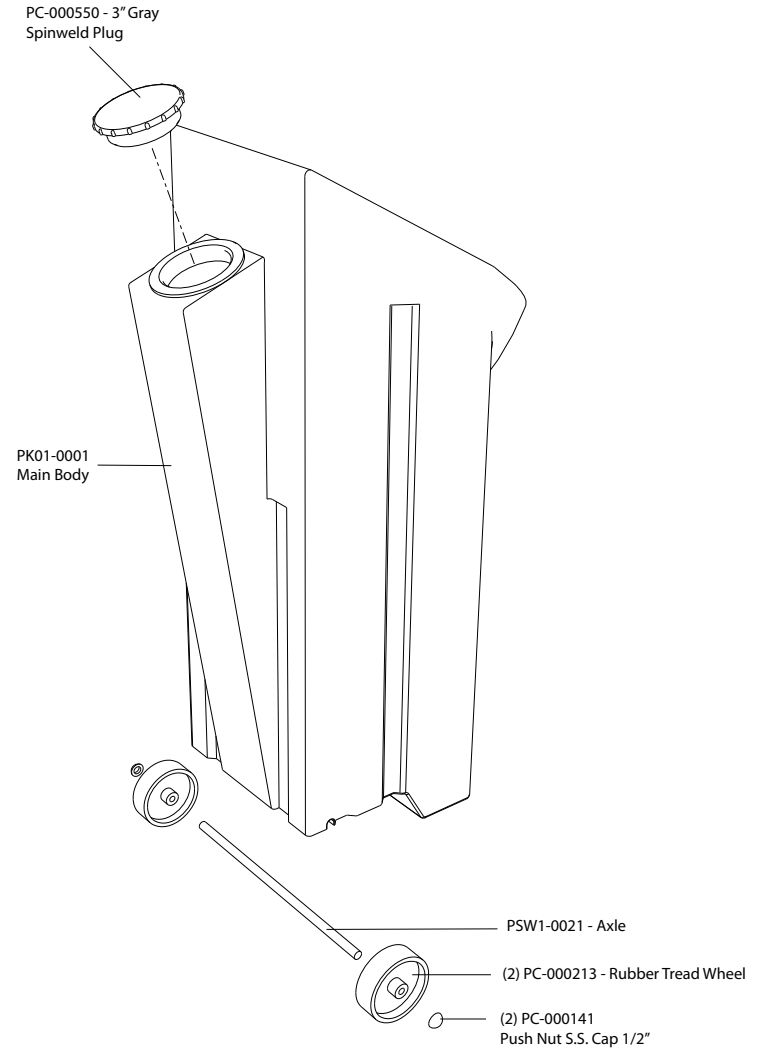
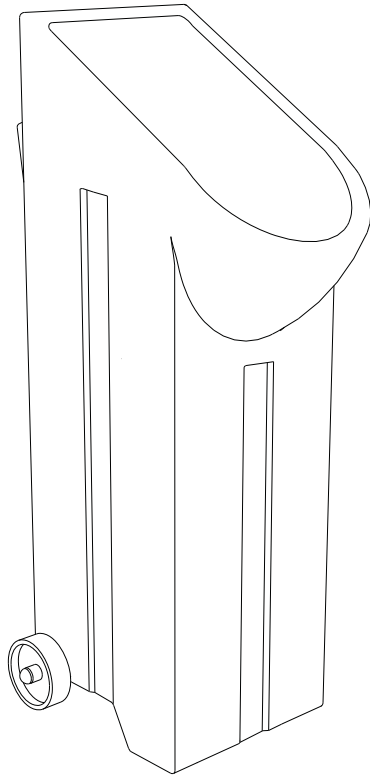

POLYJOHN USA

PolyJohn Enterprises Corp
2500 Gaspar Ave.
Whiting, IN 46394
Phone: 800-292-1305
Fax: 219-659-0625
www.polyjohn.com
info@polyjohn.com

POLYJOHN WORLDWIDE

PolyJohn (UK) Ltd.
Equinox 1 Audby Lane
Wetherby, England LS22 7RD
Phone: 44 (0) 1937-583333
Fax: 44 (0) 1937-583322
sales@polyjohn.co.uk

POLYJOHN CANADA

PolyJohn Canada
P.O. Box 2300
199 Forest Plain Rd.
Orillia, Ontario LV3 6S2
Phone: 800-465-9590
Fax: 705-325-8250
info@polyjohncanada.ca