

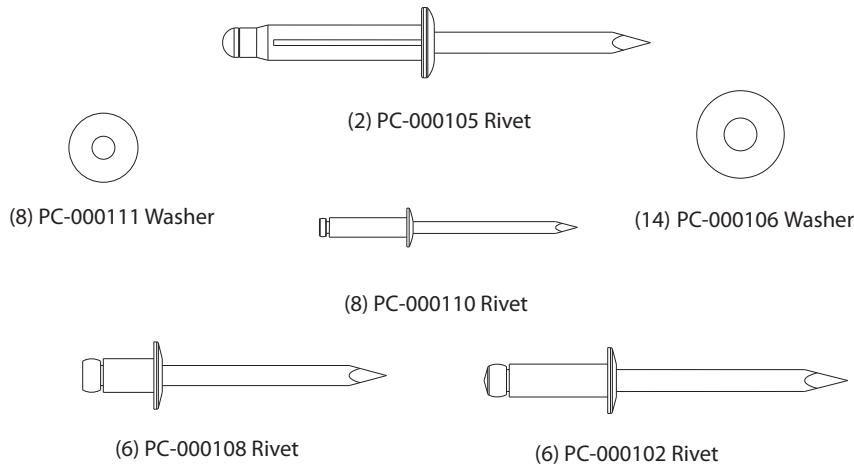

SK3 Applause™ Retro Fit Conversion Kit SK2-1000 to SK3-1000

Full Size Scale Fasteners



~~Assembly Tools Required~~

- Tape Measure
- Drill
- Phillips Screw Driver
- 9/64" & 13/64" Drill Bits
- Rivet Gun
- 7/8" Hole Saw

POLYJOHN USA
PolyJohn Enterprises Corp
2500 Gaspar Ave.
Whiting, IN 46394
Phone: 800-292-1305
Fax: 219-659-0625
www.polyjohn.com
info@polyjohn.com

POLYJOHN WORLDWIDE
PolyJohn (UK) Ltd.
Equinox 1 Audby Lane
Wetherby, England LS22 7RD
Phone: 44 (0) 1937-583333
Fax: 44 (0) 1937-583322
sales@polyjohn.co.uk

POLYJOHN CANADA
PolyJohn Canada
P.O. Box 2300
199 Forest Plain Rd.
Orillia, Ontario LV3 6S2
Phone: 800-465-9590
Fax: 705-325-8250
info@polyjohncanada.ca

Assembly Instructions

STEP 1

Drain sink entirely of fresh & gray water. Remove the (9) phillips screws that secure the existing top. Install (6) PC-000108 rivets & (6) PC-000106 back-up washers into exposed holes on top of sink bowl. Disconnect and discard the existing tubing connecting the spigots to the bottom of the tank.

STEP 2 - RELOCATE TRASH CHUTES

Refer to Figure 1.

Drill out the rivets holding the chutes on. Align the chutes (*the bottom of chute opening will be in line with the top of the tank as shown*). Use TOP HOLES in chutes as a guide. Mark the location for new holes on TANK. Drill holes using a 13/64" drill bit. On INSIDE of the tank align the chutes with the NEW TOP HOLES. Mark the location for the BOTTOM HOLE on the CHUTES. Drill holes using a 13/64" drill bit. Reattach chutes to sink tank with (2) PC-000102 rivets in the top holes & (1) PC-000104 rivet in the bottom holes. Back up rivets with (3) PC-000106 washers. Repeat process on opposite side.

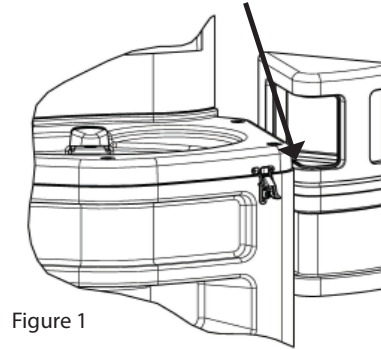

Figure 1

STEP 3 - INSTALL HINGES

Refer to Figure 2.

Align hinges as shown. Use holes in hinges as a guide. Drill holes using a 13/64" drill bit. Attach hinges with rivets as indicated.

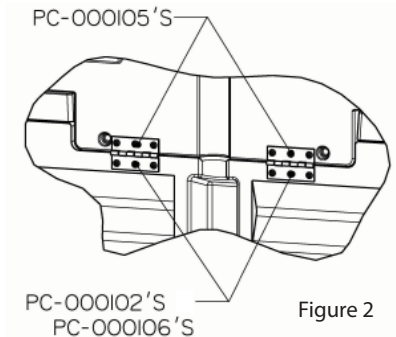

Figure 2

STEP 4 - INSTALL TETHERS

Refer to Figures 3 & 4.

Drill four 13/64" holes to mount the tethers (*as shown in Figures 3 & 4*). Attach tethers to the bottom of sink bowl with (2) PC-000105 bulbex rivets & to the inside of the sink tank with (2) PC-000102 rivets & (2) PC-000106 back-up washers.

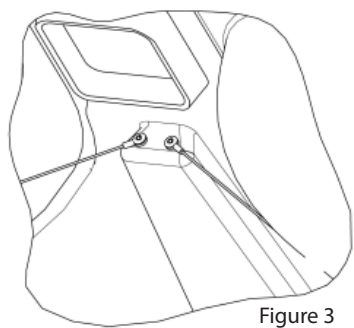

Figure 3

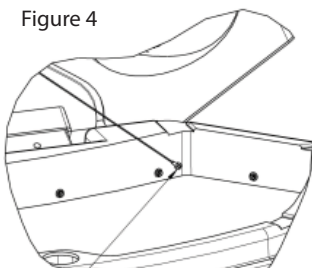

Figure 4

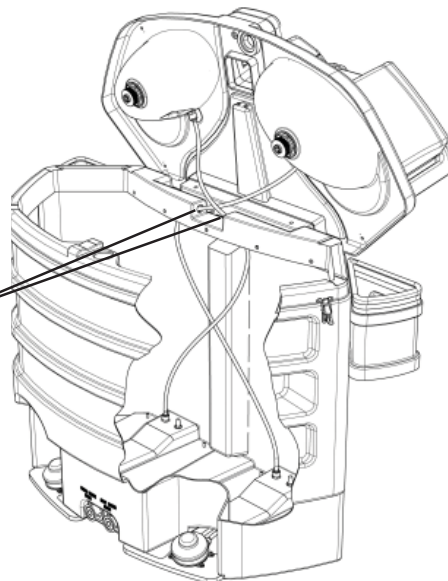

Figure 5

STEP 5 - INSTALL 65" TUBING

Refer to Figure 5.

Drill 7/8" holes where tubing comes through tank to attach to spigots. Attach & route tubing as shown.

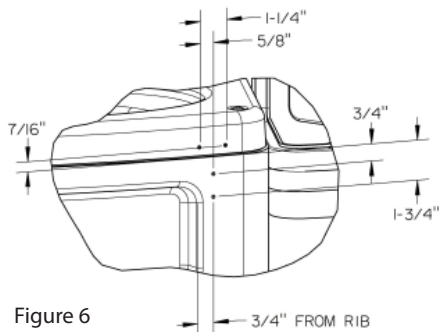

Figure 6

STEP 6 - INSTALL LATCHES & CATCHES

Refer to Figure 6.

Measure as indicated. Use a 9/64" drill bit to drill holes. Attach latches to base of sink FROM OUTSIDE with (2) PC-000110 rivets & (2) PC-000111 washers. Attach catches to bowl of sink FROM INSIDE with (2) PC-000110 rivets & (2) PC-000111 washers. Repeat process on opposite

side. Close the lid and fasten locks at latches. Conversion is complete.

Winterizing

- Drain all water from the tanks.
- Depress the foot pump to clear lines.
- Flush tank with a solution of chlorine and water.

CLEANING AND MAINTENANCE

Use a mild soap to clean all surfaces and component parts.

Minor scratches and abrasions can be lightly sanded or scrubbed with a mild abrasive cleaner (such as "Soft Scrub") that contains calcium carbonate, hypochlorate bleach and detergents. Be sure to follow the cleaning product directions since these ingredients may cause hazardous gases when mixed with other chemicals. Rinse the cleaned area and buff with a conventional wax.

Some light scratches may also be hidden by using an industrial hot air gun.

To keep the water fresh add a "Fresh Sink Tablet" (chlorinated tablet) each time the sink is filled with water.

For a source of cleaning, deodorizing and paper products contact:

RID IT
2500 GASPAR AVE.
WHITING, IN 46394-2175
800-292-1305 EXTENSION 514
www.rid-it.com

We highly recommend membership in the Portable Sanitation Association International (PSAI); the worldwide authority on portable sanitation services. The PSAI, "Portable Sanitation Industry Certification Program" manual contains a wealth of information on standards and service procedures. For more information contact the PSAI:

PORTABLE SANITATION ASSOCIATION INTERNATIONAL (PSAI)
 7800 METRO PARKWAY, SUITE 104
 BLOOMINGTON, MINNESOTA 55425 USA
 800-822-3020 / 612-854-8300 FAX 612-854-7560
 www.pesai.org

MISSION STATEMENT

"PolyJohn is a family owned, state of the art, plastics manufacturing company dedicated to providing its employees with a work environment committed to excellence, and its customers with innovative products, services and technology that meet or exceed their requirements."

THANK YOU FOR PURCHASING POLYJOHN PRODUCTS!

Look for us on the Web @ www.PolyJohn.com